

**PLEASE PUT THIS
OPERATOR'S MANUAL
IN THE DRIVERS CAB**

Edbro

Member of **JOST**-World

For a full list of Edbro Service Agents and
Distributors, please refer to:
www.edbro.com/dealerlocator

JOST UK Ltd, Edbro House, Nelson Street,
Bolton BL3 2JJ
UK Tel: 0044 (0)1204 528 888

To view the JOST World network,
please refer to:
www.jost-world.com

JOST Werke, Siemensstr.2, 63263 Neu-Isenburg
Germany Tel: 0049-6102-295-0

Edbro publication - Modified Dec 2019. Ref. number E5322/2

E5322/2

Edbro

**OPERATOR'S
MANUAL**

CONFORMS
WITH
EUROPEAN
REGULATIONS

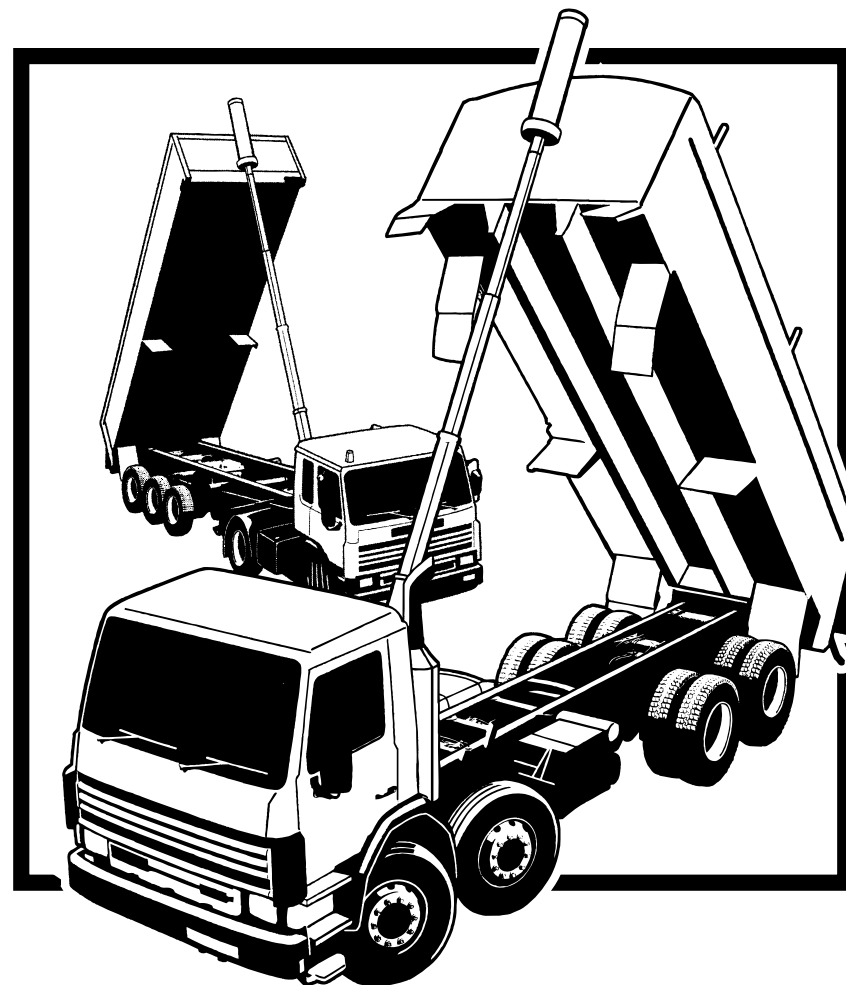

**CX & CS 07,11,13,
14 & 15 HOISTS** **Edbro**



Member of **JOST**-World

JOST UK Ltd

Edbro House, Nelson Street, Bolton, Lancashire, BL3 2JJ, England

Tel: +44 (0) 120 452 8888 Fax: +44 (0) 120 453 1957 Web: www.edbro.com Email: postmaster@edbro.com

DECLARATION OF INCORPORATION

Edbro ISO 9001 Registration Number: 4978

Description of Equipment												
C SERIES HOISTS FOR RIGID CHASSIS												
CS07	CS10	CS11	CS13	CS14	CS15	CX07	CX10	CX11	CX13	CX14	CX15	

EQUIPMENT SUPPLY ONLY

This is to certify that the above equipment complies with all relevant essential safety requirements of the EC Machinery Directive 2006/42/EC and the national laws and regulations adopting this directive.

Further information relating to conformity is available on request.

This equipment must not be put into service until the machinery into which it is incorporated has been declared in conformity with the provisions of the above directive and all relevant EC directives and appropriately CE marked.

To confirm the suitability of this equipment for the application proposed, email details to applications@edbro.co.uk.

The quality assurance arrangements adopted in respect of these products have been in accordance with the conditions of our ISO9001 registration.

For technical documentation refer to www.edbro.com or your local sales office.

Conformity assessment procedure followed: Internal control of production.

Name of person authorised to sign on behalf of the manufacturer: G D Creamer

Position: Technical Director

Signature:

Date: January 2015

Ref. QCP131-v3

Registered Office: Nelson Street, Bolton, No. 283933 United Kingdom

This is an example of our Declaration of Incorporation. If you require an individual copy for your technical file, call Edbro Sales.

Record your hoist details below:
(refer to hoist serial plate - see page 3)

Hoist model code;

Hoist serial number;

Date put into service;

PROBLEM SOLVING

THE BODY STOPS ON THE WAY UP

Lower the body as slowly as possible. Then make sure:

- the body is not overloaded or badly distributed
- the oil in the tank is up to dipstick level (refer page 16).

THE BODY WILL NOT STAY UP WITH THE TIPPER LEVER IN 'HOLD'

Put the tipper lever back in 'raise' and lift the body. Then:

- rev the engine until the relief (overload) valve blows, i.e. until you hear a high pitched noise coming from the tipper valve (page 3)
- keep the engine revs going for five seconds
- put the tipper lever in 'hold'.

If the body still will not stay up, lower the body.

EXCESSIVE NOISE

- check the oil level
- check pipes for kinks and leaks.

CONTENTS

• Correct use	1
• Identification	2
• Familiarisation	2, 3
• Safety	4
• Operating pressure	5
• Safety code	6, 7
• Controls	8, 9
• How to lift the body	10
• How to lower the body	11
• When driving	11
• Safety during maintenance	12
• Maintenance	13, 14, 15, 16
• Oil (and filling the oil tank)	17
• Bleeding the system	18
• Problem solving	19, 20

CORRECT USE

This hoist is designed to be assembled into a tipping vehicle for the movement of bulk commodities. This manual is intended as a general guide for safe tipping but more specific safety guidance should be supplied by the bodybuilder depending on the nature of the equipment. The bodybuilder can also advise on the maximum load capacity of the equipment, bearing in mind the hoist capability and road traffic regulations.

COPYRIGHT

No part of this publication may be reproduced or transmitted without the express written permission of JOST UK Ltd.

IDENTIFICATION

The hoist cylinder type is identified by a serial number plate on the inlet feed port of a CS separate ram/tank hoist or on the side of the oil tank on a CX combined ram/tank hoist. (see opposite)

The serial number and model code should be quoted in all correspondence.

The date of manufacture is quoted as a week number/year.

Serial numbers for Edbro PTO and pumps are stamped on the casing or on a separate plate.

FAMILIARISATION

Before using this equipment, familiarise yourself with the key features opposite. The position of the hydraulic parts may vary depending on specification.

Before putting into service, confirm that the equipment is in good working order.

Check:

- hoses and fittings for abrasion and leaks
- check security of hoist and hinge mountings
- check oil level
- check PTO engaged warning light is working.

PROBLEM SOLVING

The following action can be taken without special tools. If unsuccessful, call your nearest Edbro service dealer (refer list pages 20-24).

THE HOIST IS JERKY OR SLUGGISH

Air may be trapped in the system. Check oil level and then operate the hoist to full stroke several times; any air will be dissipated back to the tank. (see page 17)

THE BODY WILL NOT TIP

Make sure:

- the vehicle air pressure has had enough time to build up (see vehicle operator's manual)
- the oil in the tank is up to dipstick level (refer page 16)
- the PTO switch is 'in' and PTO is engaged (oil is circulating)
- the tipper lever is in 'raise'
- there are no kinks in the oil pipes
- the quickly detachable couplings of the tractor and trailer, where applicable, are clean and screwed together tightly
- no air is leaking from the air pipes.

THE BODY WILL NOT LOWER

Check PTO has disengaged and warning light is out.

Put the tipper lever back in 'raise'. Then:

- rev the engine until the relief (overload) valve blows, i.e. until you hear a high pitched noise coming from the tipper valve (page 3)
- keep the engine revs going for five seconds
- lower the body (page 11).

If the body still will not come down, put the tipper lever in 'hold', PROP THE BODY, switch the PTO to 'out' and turn off the engine.

BLEEDING THE SYSTEM

Warning: Take care to guard against the escape of high pressure oil

- lift the body to about 300mm (12") above the chassis frame
- put the tipper lever in 'HOLD'
- locate the bleed screw and slacken about one turn
- the body will come down slowly and force the air out of the system
- when oil flows freely, tighten the bleed screw
- if the hoist is still jerky, or sluggish, repeat the whole procedure
- lower the body, and top up the tank with clean oil
- replace the plastic cap on top of the outer cover

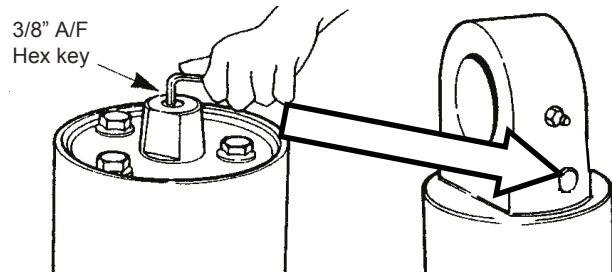

Bleeding an outer cover hoist

Bleeding an eye-ended hoist

FAMILIARISATION

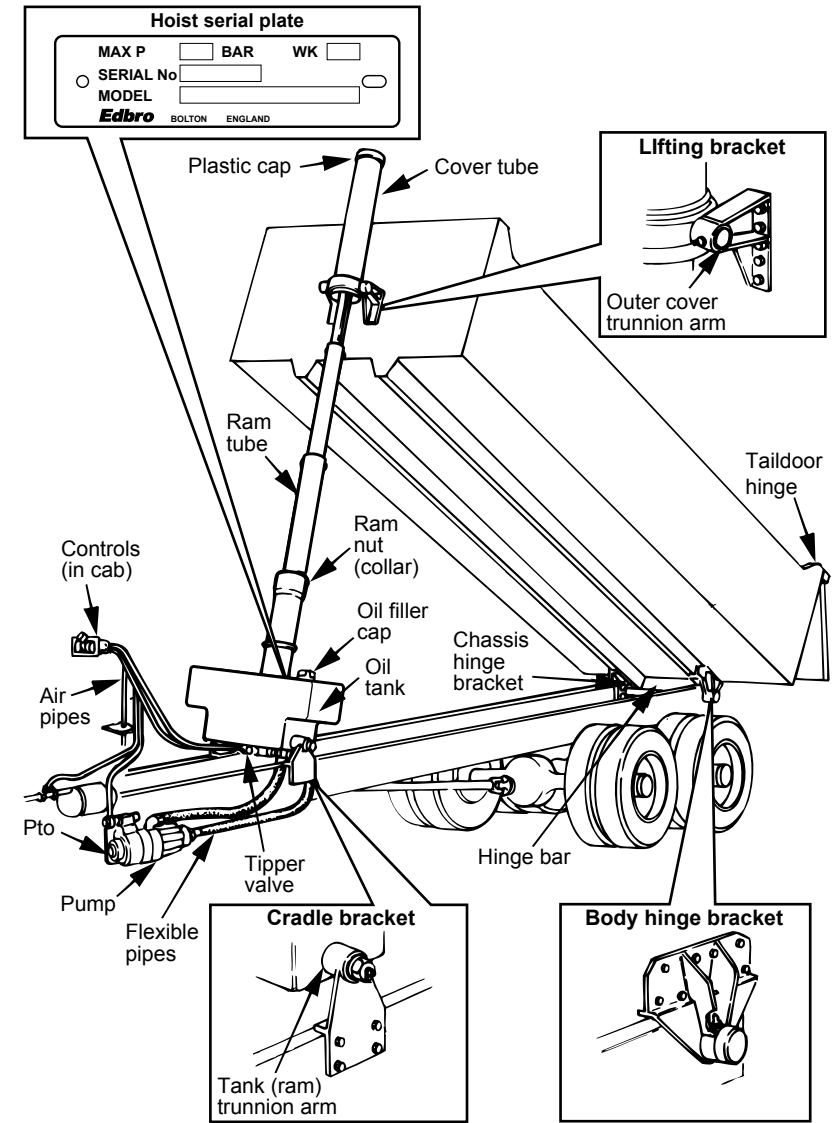

CX Combined ram and tank hoist

SAFETY

Tipping is always hazardous and sometimes dangerous.

Vehicles can be overturned by sticking loads, poor ground conditions, high cross winds or bad practices such as tipping on a side slope. So:

- do not tip until you have read and understood this manual
- remember the hoist (tipping gear) is designed to lift; it is not a stabiliser
- if the vehicle overturns, any damage to the hoist is the RESULT and not the CAUSE of the turnover
- avoid accidents by following the safety code on pages 6 and 7
- it is the responsibility of the operator to ensure that drivers are suitably trained in the use of this equipment.

OIL

Dirty oil is the enemy of a hydraulic system. The cleaner the oil, the more efficient the hoist's operation and the longer it's life. So always use clean hydraulic oil for topping up or changing the oil in the tank.

Use oil to specification ISO6734/4 HM32 for temperatures between -20°C to +30°C. Typical suitable trade names are:

CASTROL	AWS32
ESSO	VG32
GULF	HYDRASIL 32
MOBIL	DTE24
SHELL	TELLUS 32

For other climates seek advice from your local distributor or direct from Edbro.

Never put used oil in the tank. Never power wash near the breather - ALWAYS use a cloth when cleaning

To determine the oil level, remove the filler cap and check that the level is within the max./min. marks as shown:

Correct oil level:

- not above green mark on dipstick
- not below red mark on dipstick

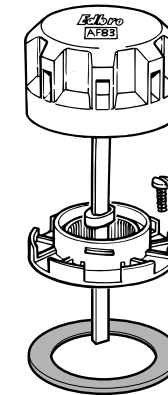
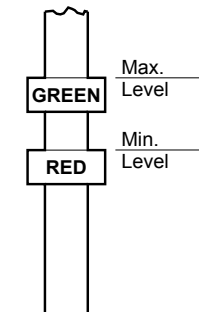

Edbro combined filler/breather assembly

BLEEDING THE SYSTEM

If the hoist judders in 'LOWER', or the tubes operate out of sequence when lowering, there may be air in the system. For early cylinders without a bleed screw (approximately, serial numbers before LG017000 / LH002100) bleed the system as follows:

- loosen the pressure outlet hose from the pump a little

MAINTENANCE

ANNUAL INSPECTION OF OUTER COVER ASSEMBLY

For older cylinders it is important to check for corrosion of the outer cover tube in the area behind the trunnion ring. This is particularly important where the equipment is used in a coastal/salty environment or is regularly power washed.

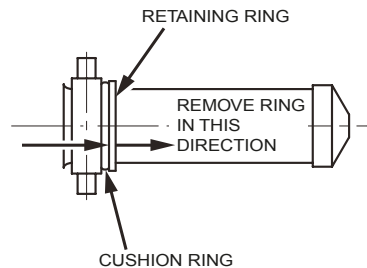

PROCEDURE

1. Remove rubber anti-rattle ring by levering out above top retaining ring.
2. Visually inspect the exposed tube for signs of excessive corrosion.
3. Serious scaling or perforation requires the cover to be replaced.
4. Return the rubber cushion ring to the normal position after inspection.

Depending on the specification of your equipment, other maintenance checks may be required. These should be advised by the bodybuilder/installer.

TRUNNION ARM WEAR

After some use cylinders and brackets will wear at the trunnion mountings and it will be necessary to replace some components when wear reaches unacceptable levels. The rate of wear will depend on the degree of lubrication and the type of use.

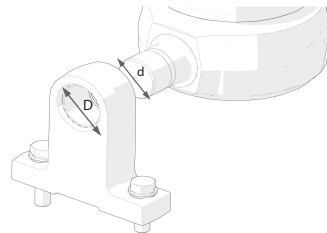

The extent of acceptable wear may also depend on the type of use but actions should certainly be taken when wear reaches 5% of the trunnion diameter.

$$D - d = 5\% \text{ of trunnion diameter } d$$

This is typically 3mm total wear. Action to be taken could include:-

1. Replacing bracket bushes (if fitted)
2. Replacing brackets completely
3. Replacing the cylinders base tube assembly

OPERATING PRESSURE

This hoist must only be operated up to a maximum pressure shown on the identification plate. Normally this is 150 bar (2,200psi) but it may lower if there is a risk of buckling failure on long stroke hoists.

The hoist works best if the vehicle is fitted with matching Edbro hydraulics (PTO, pump, valves, oil tank, pipes and controls).

If the vehicle has Edbro hydraulics, NEVER TRY TO ALTER THE PRESSURE SETTING OF THE RELIEF (OVERLOAD) VALVE. The valve is preset at the factory.



SAFETY CODE

ALWAYS

- keep the tyres at the correct pressure
- spread the load evenly in the body
- before tipping make sure your truck is on firm, level ground
- make sure the danger area is clear of people and obstructions (refer opposite)
- during tipping, stay in the cab at the controls; if danger signs develop (for example, if the body starts to lean to one side or the load sticks) immediately lower the body
- prevent the discharging load from piling up and fouling on the taildoor by driving forward **VERY SLOWLY BY NO MORE THAN A METRE AT A TIME**
- just before loading, move the control lever to lower to ensure that no oil is trapped in the cylinder and the full load rests on the chassis.

EXTRA CAUTION

Be particularly careful in frosty weather. Frost can cause wet loads to stick and discharge unevenly.

NEVER

- overload
- alter the pressure setting of the relief (overload) valve
- put the tipper lever in 'tip' unless you are actually tipping
- tip in high winds
- tip on a side slope
- tip with the body within 5 metres of overhead power lines
- shake the load free
- drive off with the body up or the PTO engaged. This could damage the equipment
- leave the body up overnight
- leave the vehicle with the ignition key in
- go under a raised **LOADED** body
- go under a raised **EMPTY** body (unless it is propped)
- steam clean or the exposed cylinder tubes, this will cause corrosion
- climb on the equipment by any means other than that provided by the bodybuilder.
- never power wash near the breather

MAINTENANCE

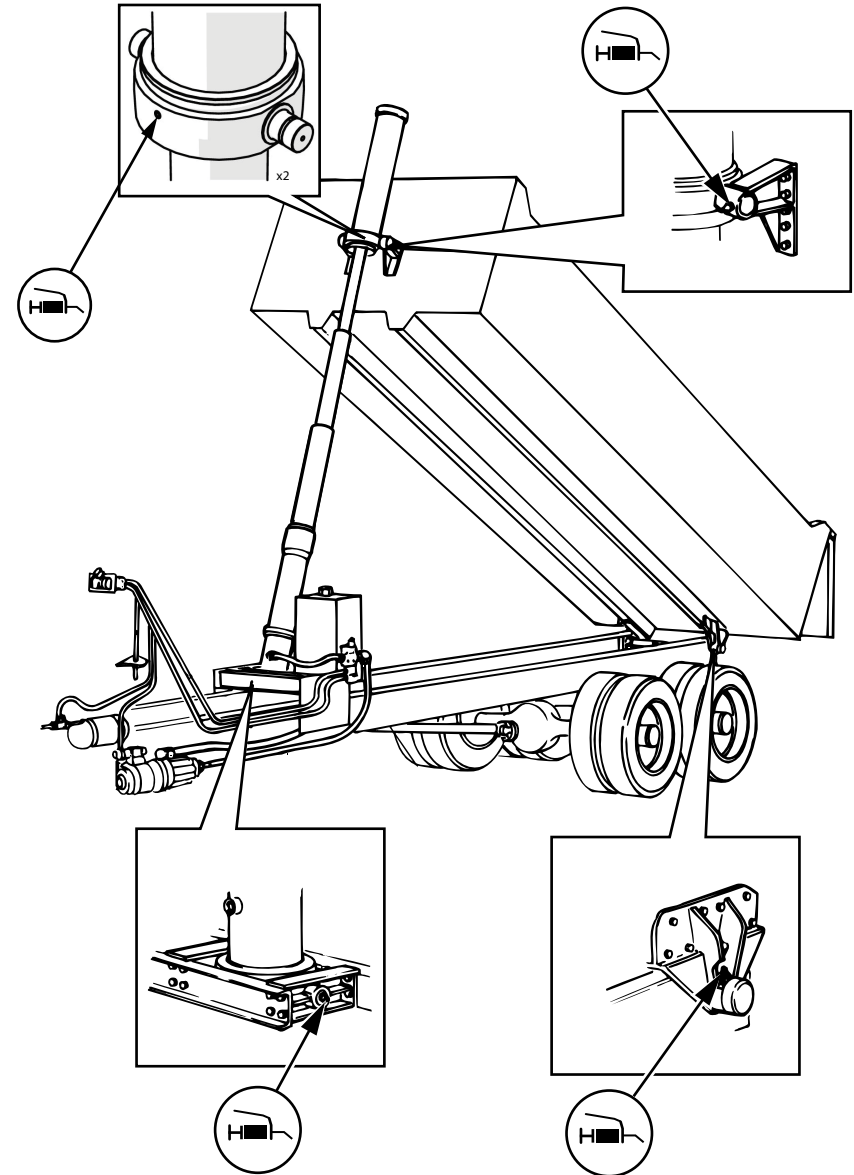

MAINTENANCE

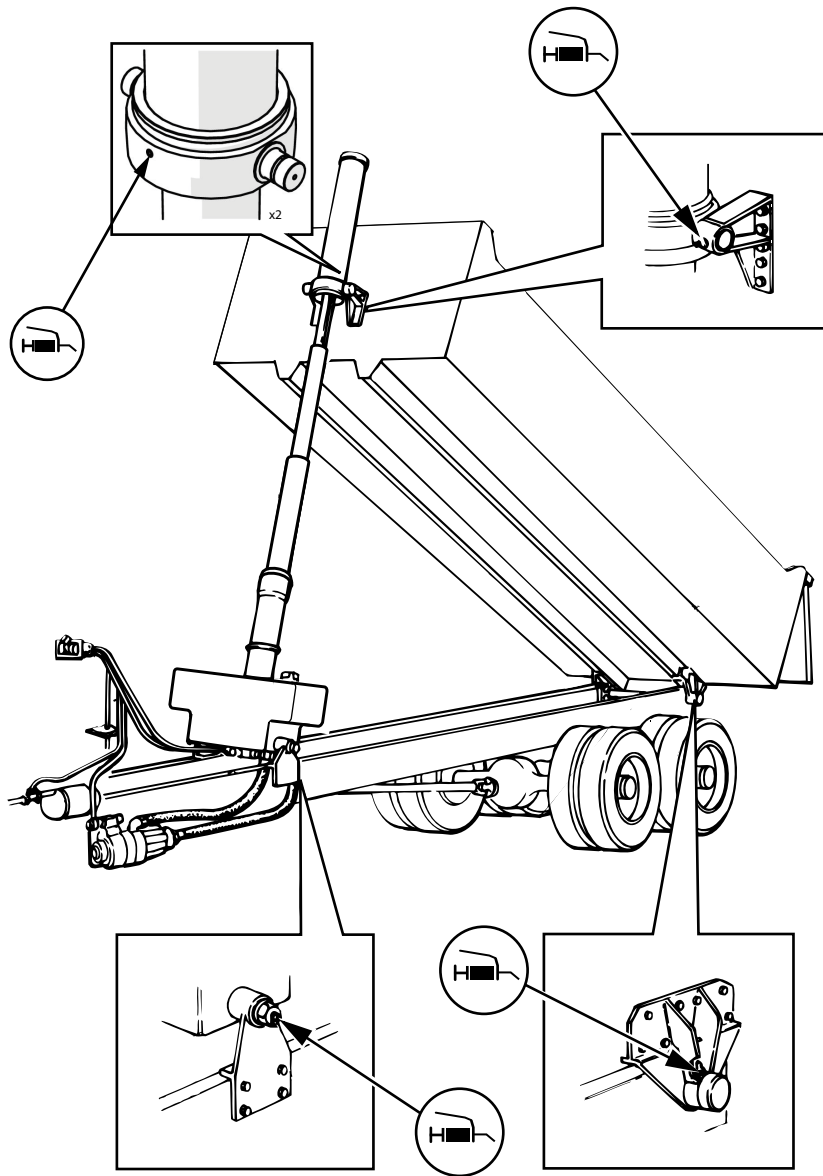

SAFETY CODE

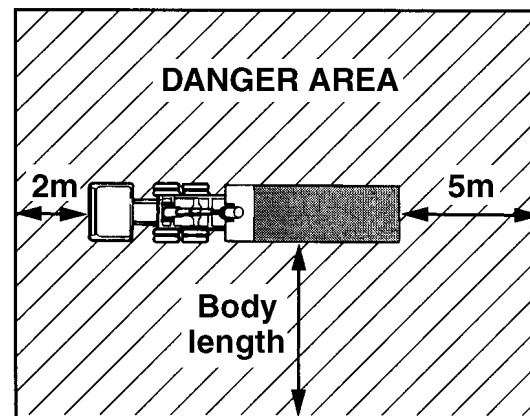
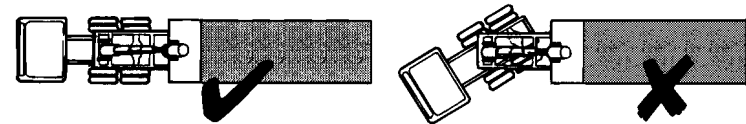
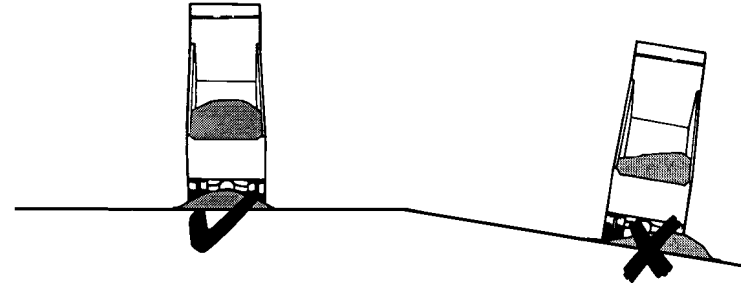
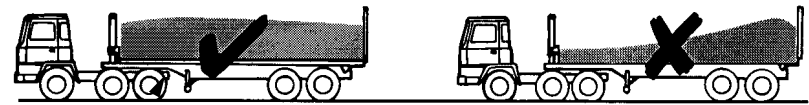

Always ensure that no person, animal or other equipment is within this area when tipping

CONTROLS

Your Edbro hoist works best if the vehicle is fitted with matching Edbro hydraulics (PTO, pump, valves, oil tank, pipes and controls).

The PTO and tipper controls are combined in one unit and work off the vehicle's air system (fig. a).

The PTO control switch is fitted with a PTO engaged warning light.

The tipper control is a lever with four safety features:

- a spring-loaded device stops it from being accidentally moved into 'raise' or 'lower'
- a spring return to 'hold' from 'raise' position, known as a deadman's handle function, ensures the driver keeps his hand on the tipper control **all the time** the body is being raised
- when the lever is moved from 'hold' towards 'lower', the PTO is automatically disengaged; this internal mechanical feature prevents PTO, pump or gearbox damage if you forget to disengage the PTO before driving off
- controlled lowering (feathering) regulates speed of descent for loaded or part-loaded bodies.

This type of control is recommended for conformity with European standards. Other controls are available but, if used, the bodybuilder will need to ensure that all Essential Safety Requirements are covered by other means. For example, separate controls are available (fig. b).

*Alternative combined controls **without** automatic PTO disengagement feature (for spreading or static discharge applications) are available.

MAINTENANCE

MONTHLY

Ensure the body is down, handbrake is on and engine is switched off. Then top up the oil in the tank to dipstick level with clean hydraulic oil (refer page 16).

Use a grease gun to lubricate the points shown on pages 14 or 15 with a good quality, multi-purpose grease.

Grease the taildoor hinge and locking mechanism.

Replace any worn or damaged flexible pipes.

Make sure all flexible pipes are secured to the chassis and are not hanging loose.

Check the outer cover fixing studs are tight.

Tighten any loose pipe connections.

Check and tell your Edbro service dealer if:

- the outer cover (where applicable) is loose (side-to-side or rotating)
- any ram tube is damaged
- the base ram nut is loose
- the ram trunnion arms, the outer cover trunnion arms, or the rear hinge brackets are worn
- oil is leaking from the ram tubes, tipper valve, PTO, pump or flexible pipes
- air is leaking from the air pipes or control unit

THREE MONTHLY

Use spanners to check the tightness of the fixing bolts on the tipper valve, PTO and brackets.

YEARLY (more often in dusty or dirty conditions)

Drain and refill the tank with clean hydraulic oil (refer page 16). In order to protect the environment, ensure that no oil is spilled when draining, and old oil is disposed of correctly.

Depending on the specification of your equipment, other maintenance checks may be required. These should be advised by the bodybuilder/installer.

SAFETY DURING MAINTENANCE

A body prop is considered by Edbro to be an Essential Safety Requirement. A prop must always be used if maintenance needs to be undertaken with the body raised.

- never attempt to prop a loaded body
- use a prop designed to locate securely between the body underframe and chassis
- the prop must be between body and chassis, not between the body and the ground
- lower the body gently onto the prop to minimise damage
- confirm that the prop is sufficiently strong to carry the bodyweight.



IT IS THE OPERATOR'S RESPONSIBILITY TO ENSURE THAT ONLY FULLY TRAINED PERSONNEL REPAIR OR SERVICE THIS EQUIPMENT. IF NECESSARY, CONTACT YOUR LOCAL SERVICE AGENT FOR ASSISTANCE.

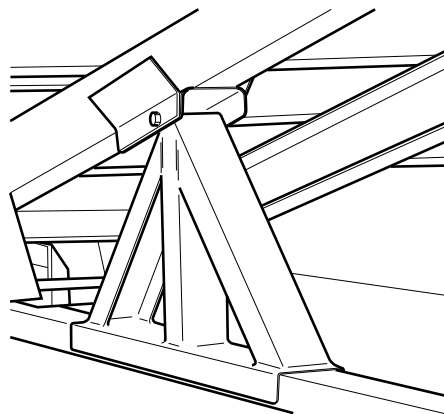

Typical body-prop arrangement

CONTROLS



Fig. a. Combined PTO & tipper air controls



Fig. b. Separate tipper air control

HOW TO LIFT THE BODY

Make sure the handbrake is on, the gear lever is in neutral, the tipper lever is in 'hold' and the PTO switch is 'out'. Then:

- unlock the taildoor or grain hatch (taking care to stand clear)
- return to the cab, start the engine and make sure the air pressure is at the level recommended by the manufacturer
- remain in the cab until the tipping operation is complete
- depress the clutch* and wait 4 seconds (8 seconds for a gearbox with a rear mounted PTO)
- press the safety latch and switch the PTO 'in' (the warning light will come on)
- release the clutch
- make sure no-one is within the danger area (see page 7)
- move the tipper lever to 'raise' and hold in position. Releasing pressure on the lever will stop the body lifting
- raise the body SMOOTHLY by varying the engine revs **NEVER EXCEED 1100rpm**
 - Higher engine revs may be possible depending on the PTO / pump model & the gearbox model. Check with your supplier to be sure.
- prevent the discharging load from piling up and fouling the taildoor by driving forward VERY SLOWLY BY NO MORE THAN A METRE AT A TIME
- when the body gets to the tipping angle you want, release the tipper lever to 'hold'
- if you need to spread the load, release the handbrake and drive forward VERY SLOWLY.

* If you have an automatic gearbox, the PTO operation will be different. Refer to the PTO installer for specific instructions.

 **Warning :** Maximum engine revs therefore pump revs & flow should be limited by the application in the first instance & then by the limit of the pump & the suction line size used. Excess speed can cause damage to the pump & gearbox. Refer to edbro for support & advice on maximum pump speeds.

HOW TO LOWER THE BODY

Make sure that no-one is in the danger area (see page 7). Then:

- SLOWLY move the tipper lever out of 'hold' towards 'lower'; this will automatically disengage the PTO and the warning light will go out. If automatic PTO disengagement is not fitted, switch the PTO to 'out' before driving off
- regulate the speed the body comes down by moving the lever towards 'hold' to slow it down or towards 'lower' to speed its descent
- when the body is down, move the lever back to 'hold'
- lock the taildoor



DO NOT DRIVE OFF UNTIL THE BODY IS FULLY DOWN. MAKE SURE THAT THE PTO IS DISENGAGED BEFORE DRIVING OFF.

WHEN DRIVING

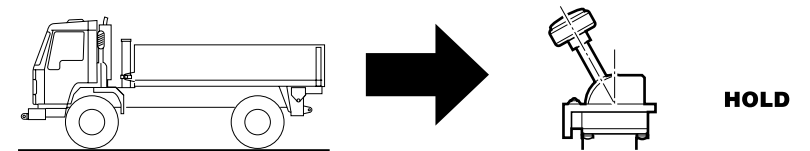

When UNLADEN leave the cab control in HOLD to minimise body bounce.

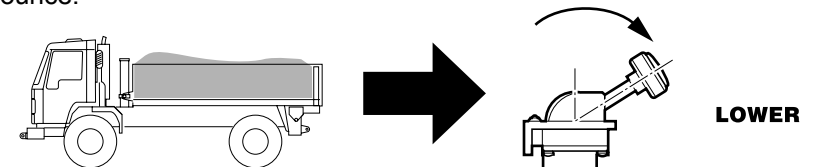

When LOADING put the cab control in LOWER to ensure that no oil is trapped in the cylinder and the entire load rests on the chassis. Then return the control to HOLD when travelling.