

Product Bulletin

Date: 18th May 2026

Subject: Transpecs UTBK Hinge Kits, UTBK-01 & UTBK-100

Over the past 12 months, Transpecs in conjunction with Transtech Dynamics Ltd, have been undertaking a project to physically test the UTBK hinge assemblies. We are well into the project and expect there will be a hinge assembly that has been tested to NZS 5446 within the next few months. Unfortunately, this has not been completed by the time our current SOC for the assembly using the 2" diameter pin expired on 1st May 2026.

At the time of publication, the RTB12 & RTB14 castings, and their respective attachment to the dolly and drawbar, have reached 4.0 million cycles at 36 ton MTM without any failures, and are still going. A full test with the current 2" pin and WT1101HD rubber bushes was unable to be completed due to failures of the rubber bushes; therefore, we are unable to demonstrate compliance with NZS 5446.

We are currently undertaking product development work to improve the hinge assembly design and useability. New bushes with a steel sleeve and stiffer rubber compound have been developed. The 2" pin and these new bushes have been successfully tested to 2.0 million cycles. The next phase of product development is to carryout in-service testing of the new bushes, and this is expected to get underway shortly.

To date, Transpecs have not been made aware of any in-service failures with the current 2" pin and bushes. Combined with the results of the physical testing, there is little evidence that the current UTBK hinge kits are a risk to public safety.

While our product development is still on-going, we are providing the attached documentation to cover the ratings and fitment instructions for the current UTBK hinge assemblies.

For copies of all documentation please see our website at www.transpecs.co.nz or contact the Transpecs customer services on 09 980 7300 or at cs@simedarby.co.nz

Regards,

Lincoln Dagnall

GM Transpecs

Drawbar Hinge Assembly Ratings

Ratings: MTM 36000 Kgs

Vertical load: N/A

Model Part Numbers: UTBK-01 and UTBK-100

Design life: 1,500,000 cycles

Application: Dolly Hinge Assembly for hinged drawbars only mounted on full trailers with one or two dolly axles. This includes convertor dollies used in full trailers.

Individual Part Numbers of Items contained within the kits:

Parts Description:	Qty:	Part number:
Equaliser Pin 51mm	2	WT1201D
Equaliser Nut	2	1416901
Equaliser Pin Washer	2	6931502
Equaliser Bushes Tapered 2"	2	WT1101HD
Drawbar Hinge Bracket*	2	RTB14
Drawbar Hinge Bracket*	2	RTB14-100
Dolly Frame Hinge Bracket	2	RTB12

*RTB14 for 75mm drawbar *RTB14-100 for 100mm drawbar.

Installation: The above ratings are only applicable when following Transpecs installation instructions RG205-2* or RG207-2*, GTSB-LG-25.03.17 and the welding instruction RTB2601

Service Limits:

- If a component is deformed, worn or damaged beyond 5% of its original dimension or profile then it shall be replaced.
- The bushes are a wearable component and should be replaced after a maximum of 1,000,000 kms.
- If the bushes are replaced earlier, it is advised to change the pin as well.
- If the hinge or drawbar is damaged or involved in an accident, it must be inspected by a suitable engineer to deem if the hinge kit is serviceable or needs replacing.

Exclusions: The ratings given on this sheet shall only apply to the UTBK-01 and UTBK-100 assemblies. They do not apply if substitute parts are used nor if the assembly is not installed as per the instructions given.

Copies of all the documentation noted above are available on the Transpecs web site or contact Transpecs customer services on 09 980 7300 or at cs@simedarby.co.nz

WELDING

- ALL WELDING TO AS/NZS 1554 SP
- SURFACES TO BE FREE OF ANY FINIS, TEARS, CRACKS, PAINT, SCALE GREASE OR ANY FOREIGN MATTER
- PROCESS - SEMI AUTOMATIC GAS SHIELDED BARE WIRE OR FLUX CORED MANUAL METAL ARC USING HYDROGEN CONTROLLED ELECTRODES
- WELDING WIRE - WELDWELL PZ6000 MIG WIRE OR EQUIVALENT
- PREFERRED OPERATOR PROCESS - DOWN-HAND
- ALL WELDING TO BE CARRIED OUT BY OPERATOR HOLDING APPROPRIATE, AS/NZS 2980 OR AS/NZS ISO9606.1.2017 QUALIFICATION IN THE APPROPRIATE WELDING POSITIONS.
- PREHEAT TO 100°C
- 100% VISUAL INSPECTION REQUIRED BEFORE CONCEALING IN ANYWAY
- UNLESS OTHERWISE STATED 6mm FILLET OR FULL PENETRATION BUTT WELD APPLIES

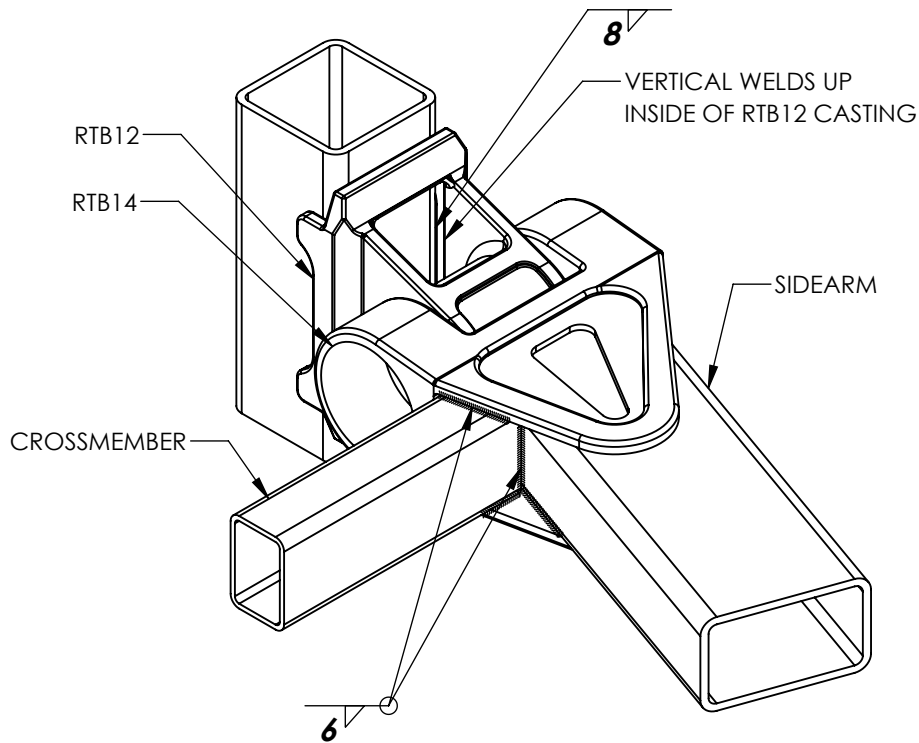
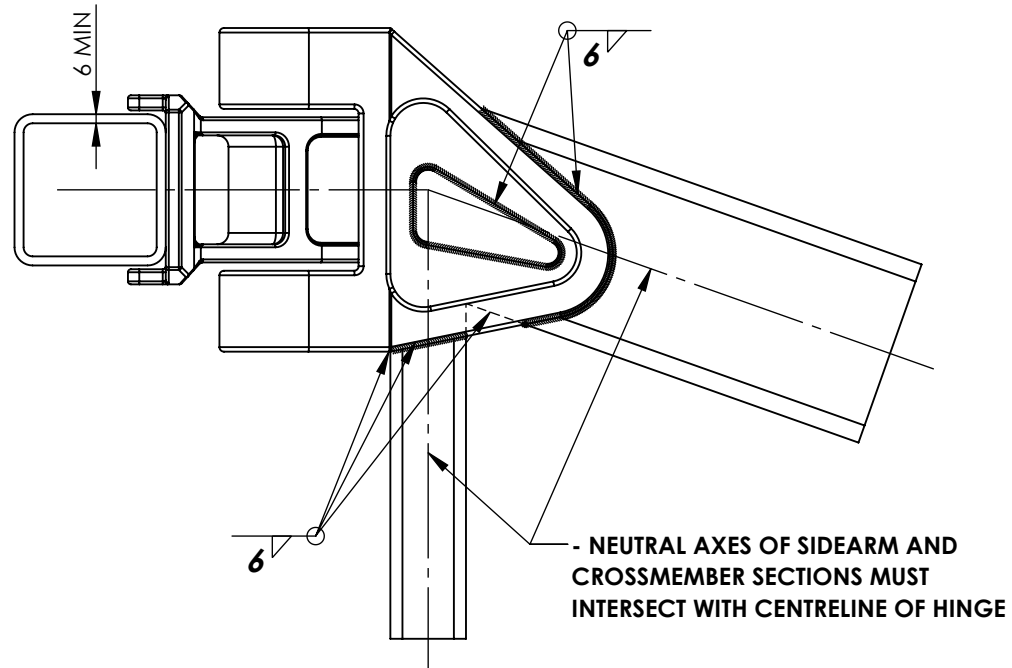
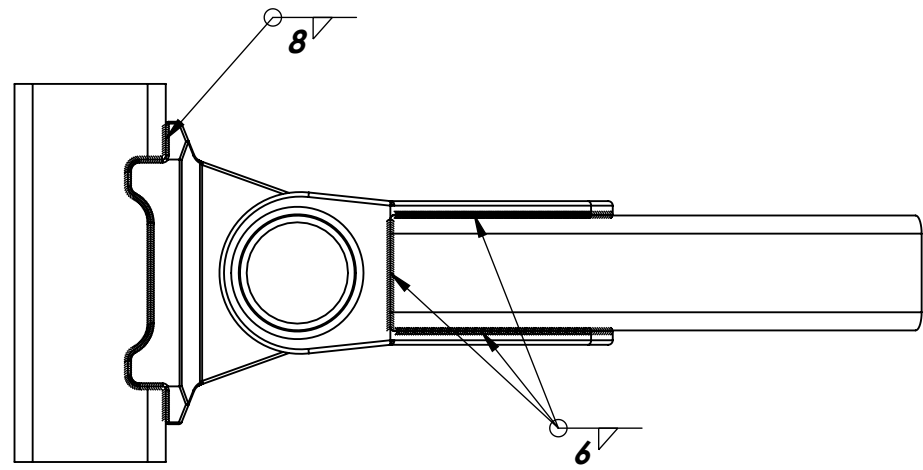

Material Specifications (Steel)		Standards
High Tensile	Minimum yield strength 650MPa	AS3597, EN-10149.2 or equivalent
Grade 350	Minimum yield strength 350MPa	AS3678 or equivalent
Grade 250	Minimum yield strength 250MPa	AS3678 or equivalent

Welding and Inspection: All burrs and sharp edges to be removed. Welding must comply with AS/NZS 1554.1:2014 and AS/NZS 1554.4:2014 as applicable. Category SP (Section 4.7) where appropriate. The welder must be qualified to AS/NZS ISO 9606.1:2017 in the relevant processes and positions. Welds to be continuous 6mm fillet or full penetration butt welds unless specified otherwise. No notches due to cutting errors acceptable on finished surfaces. Quality inspections of all welds required before any details concealed and before painting

Tolerances: Machining: ±0.05mm unless specified otherwise. General Fabrication: Up to 2.5m, ±1.0mm, > 2.5m, ±3.0mm unless specified otherwise.

TRANSPECS	
Project	UTBK HINGE ASSEMBLY
Title	WELD DETAIL

SCALE:1:5		
Drawn	Date 11/05/2026	Sheet No.
Checked	Date	SHEET 1 OF 1
Designed	Date	Drawing No. RTB2601
Approved	Date	

UTBK-01 DRAWBAR KIT

April 2024

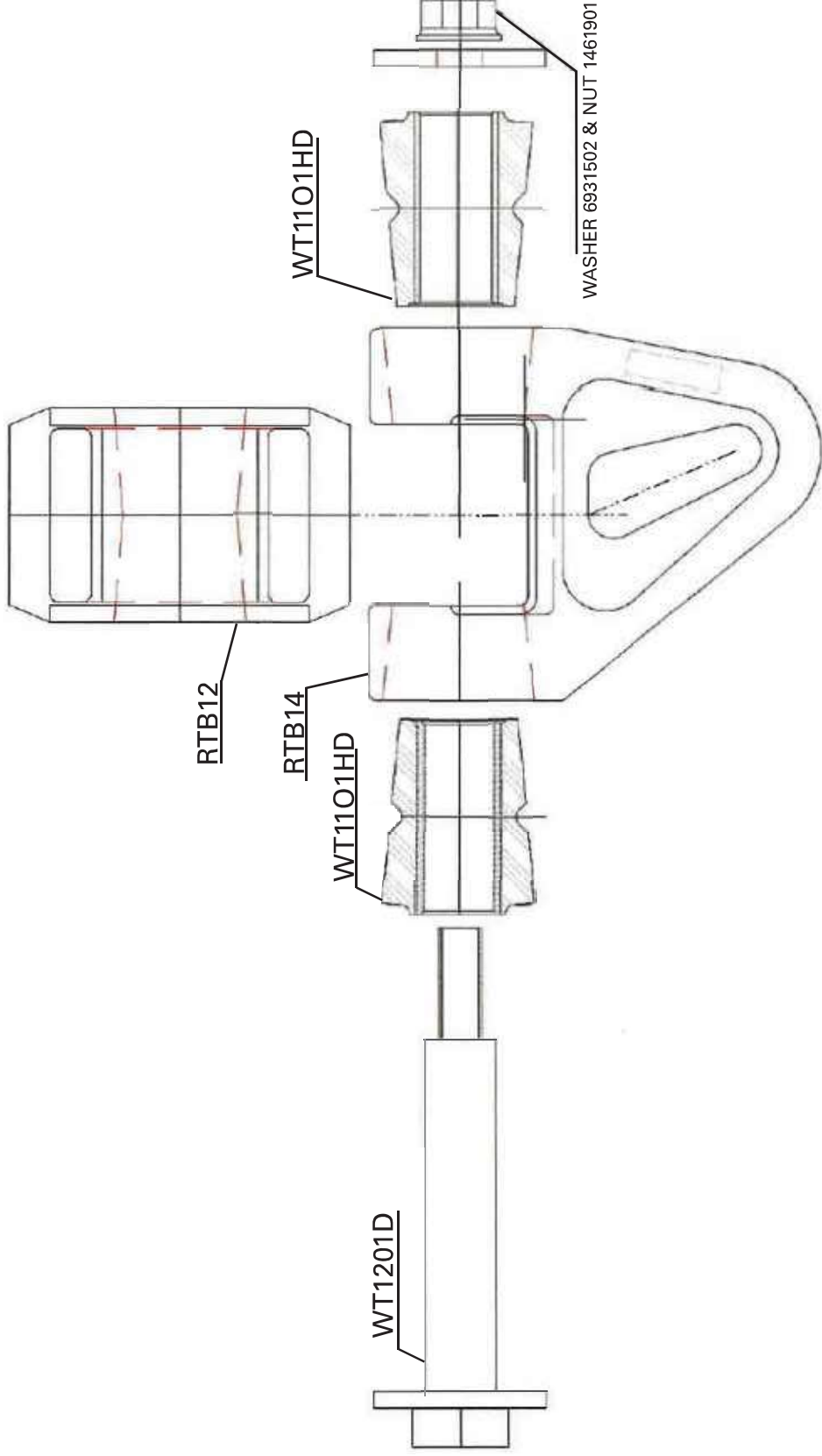

DRAWING RG205-2

UTBK-100 DRAWBAR KIT

April 2024

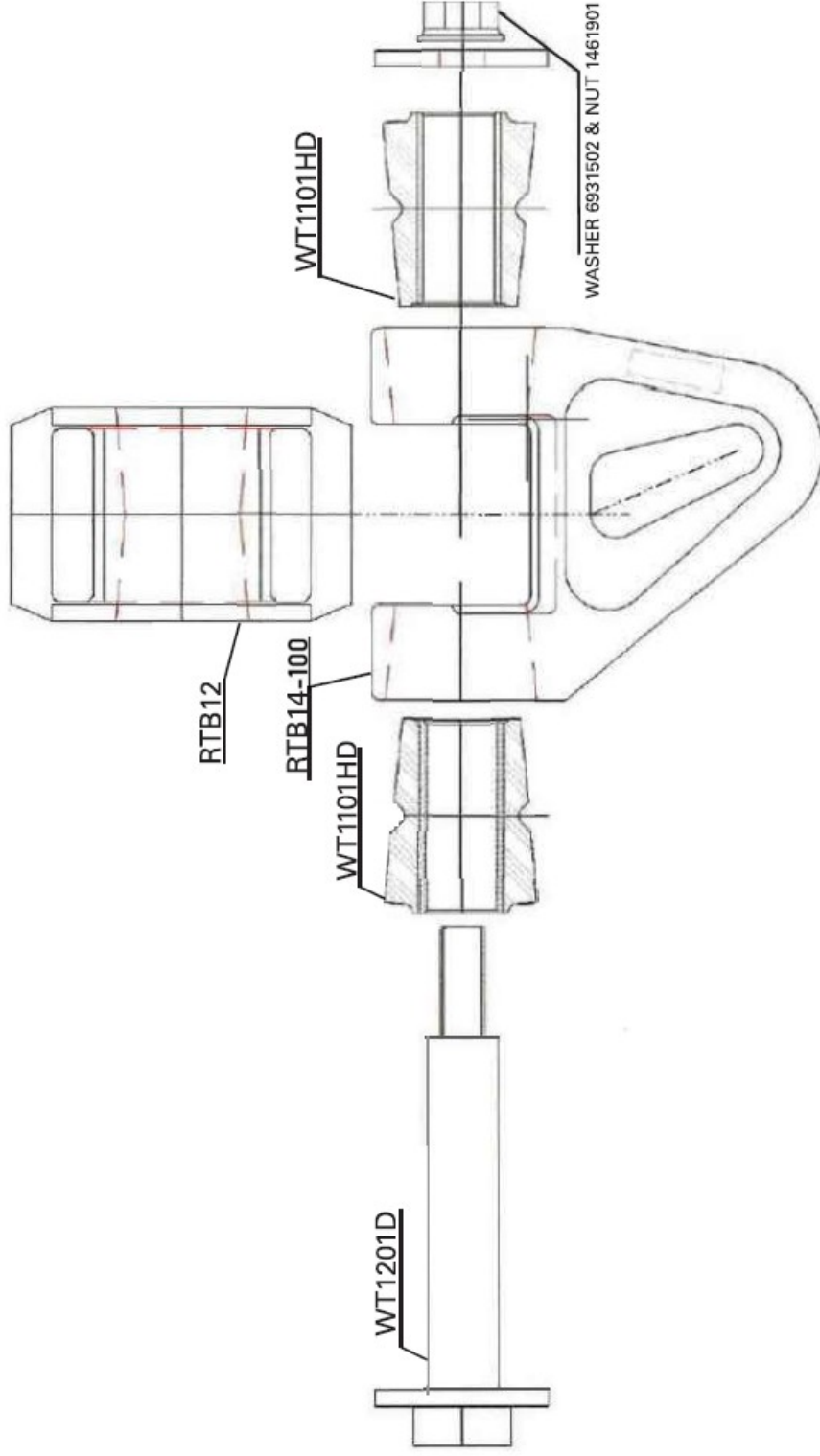

DRAWING RG207-2

 **Transpecs**

Introduction:

The correct installation of the drawbar pin WT1201D and WT1101HD plastic lined bushes is required for the drawbar hinge kit to perform as designed. The main function of the hinge kit is to perform as an elasticated joint and there should be no metal to metal contact of the RTB12 and 14 brackets.

Scope of this Bulletin:

This bulletin refers only to the WT1201D pin in relation to the Transpecs universal drawbar hinge kits – UTBK-01 and UTBK-100. Other suppliers may have similar products that interchange but that supplier will need to provide any information in relation to their products.

Certification:

The UTBK Hinge Kits supplied by Transpecs carry a certification for new installation. This certification provides for a maximum service wear limit of 5% of the original dimensions and profiles, after this the components must be replaced. If non elastic movement is found, the components require inspection and replacement of worn items. The certification is void if the installation instructions have not been followed or parts other than the original equipment items stated on the certificate are used.

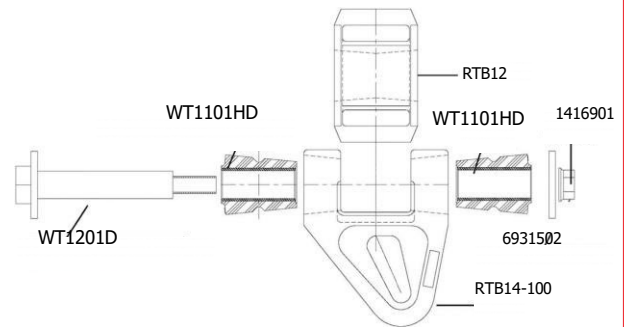

UTBK PIN & BUSH INSTALLATION

Installation of Pin & Bushes:

Ensure the bush mating surfaces on the RTB12 and 14 are free from any oil or other contamination. Install the rubber bushings "WT1101HD" through the outer RTB14 bracket to the inner RTB12. Lubricants are not recommended but if absolutely necessary, use soap and water or just plain water. DO NOT USE ANY PETROLEUM BASED LUBRICANTS.

Ensure the gaps between the RTB14 and the RTB 12 are kept equal throughout the procedure as illustrated in **Image A**. This is essential for correct installation.

Fit the WT1101HD bushes and the WT1201D, nut and washer. The shank of the pin can be coated in an anti-seize product. Ensure no lubricant is present on the threads or the washer.

NOT USING AN IMPACT GUN, slowly torque up the pin and nut to 250Nm, whilst ensuring the RTB 12 and 14 are kept an equal distance apart and inspect. This securing of this connection should also be done at the natural operating height of the drawbar when it is in service. The WT1201D is designed to be torqued only once, if the connection is undone a new pin must be used.

The main reference in the assembly of this connection is not achieving a torque figure. It is to ensure the rubber beads up in the space between the inner and outer bracket as shown in **Image B and C**. to ensure elasticity. With the WT1101HD bushes this is normally completed at a figure from 250Nm onwards up to 290Nm. There must always be rubber visible between the washers and the brackets as shown in **Images B, C and D**.

Maintenance:

Daily - A visual inspection of the hinge components should be carried out on the driver's walk-around check to identify any loose components and any worn items (e.g. washer touching hinge bracket, loose washer etc).

Vehicle Service Inspection - As well as a visual inspection, the connection should be checked for wear and security on every vehicle service or at least 3 months or 30,000kms whichever is first. If any non-elastic (i.e. loose) movement is found, all components should be inspected for wear and faulty components replaced. Do not just tighten the nut. If undone always use a new pin and nut.

The inspection frequency should be determined by the operator in line with the conditions they operate in, but the UTBK hinge should be inspected at least every 30,000kms or 3 months.

In case of an accident that involves excess force being applied to the drawbar, follow the direction of the certifying engineer, though as a minimum the pin, nut, washer and bushes should be replaced.

